

Wiring Configuration

INSTALLATION ADDENDUM

ADVANCED MODELS (HE150/HE250/HE300)

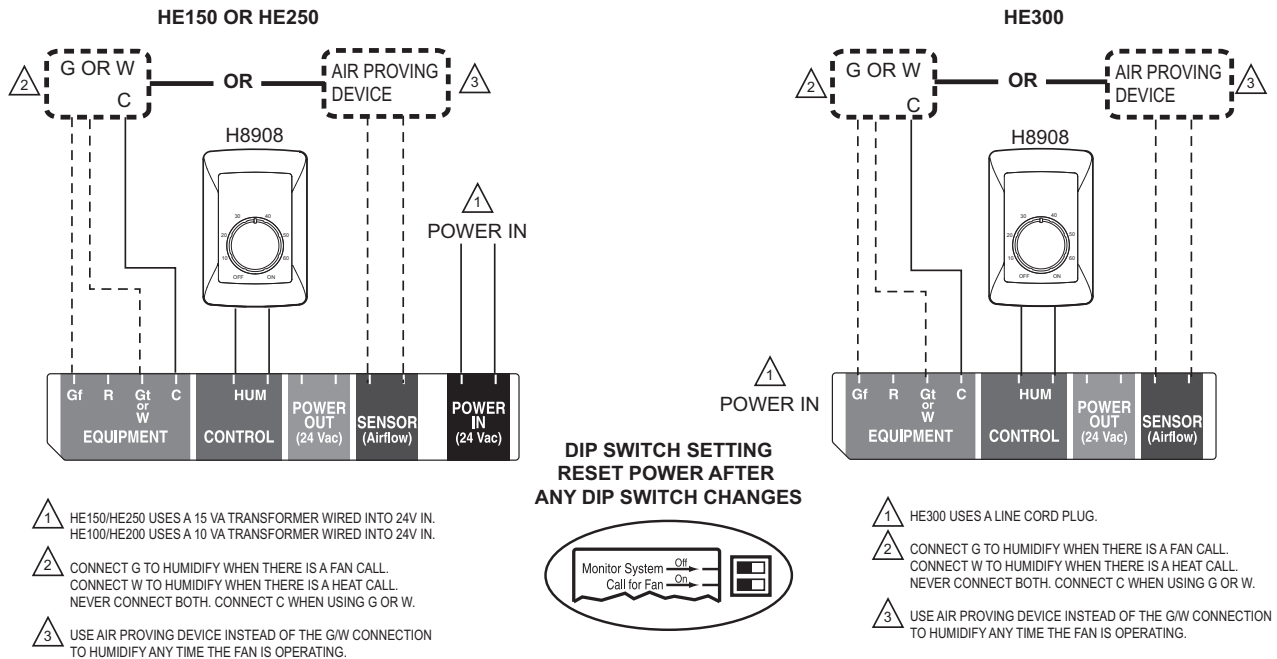

M29938A

Fig. 1. Wiring H8908 to humidify only with a call for heat or fan.

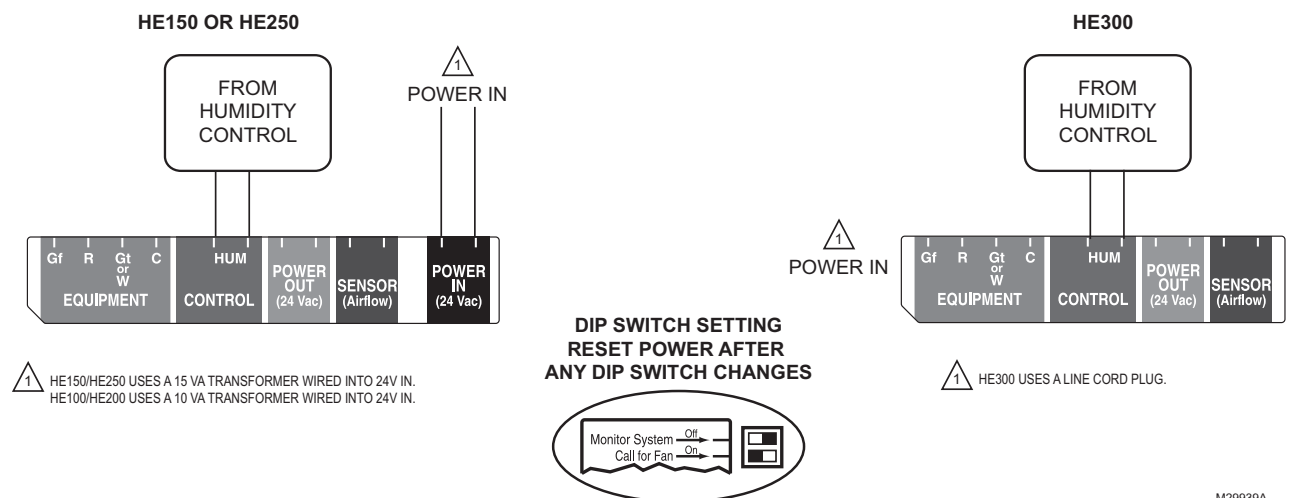

M29939A

Fig. 2. Wiring TrueIAQ, VisionPRO IAQ, or Prestige, using the intelligent control to program humidity calls with heat, cool, or on demand.



WIRING CONFIGURATION

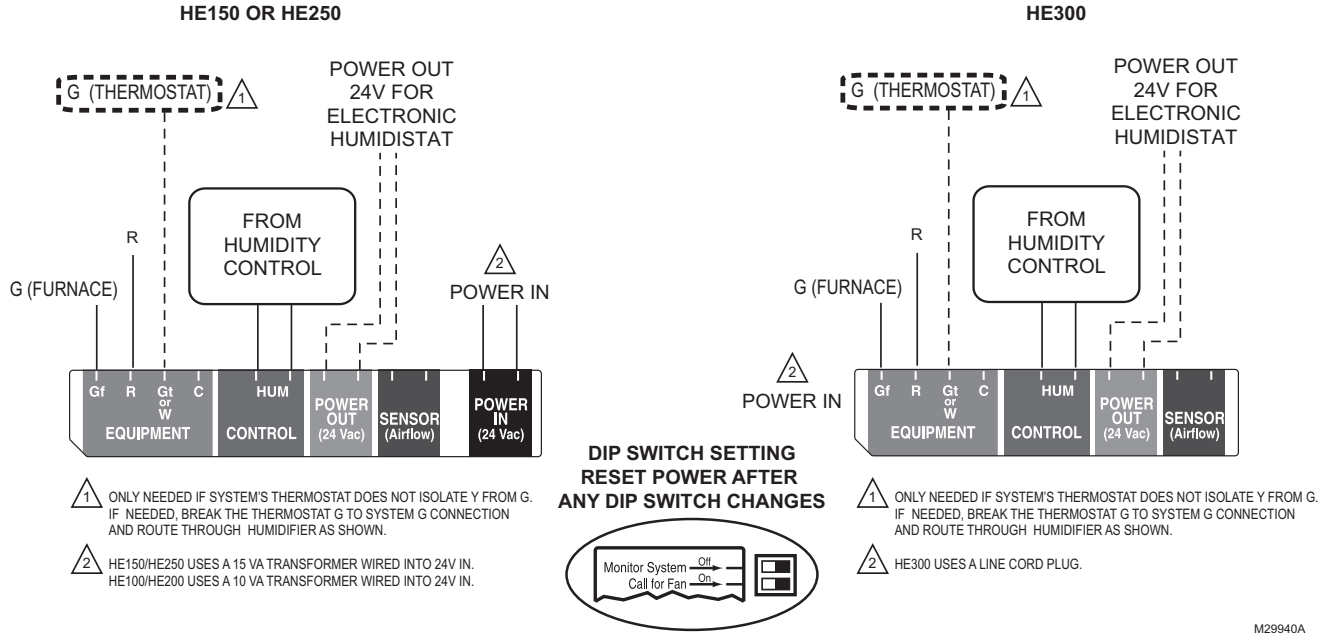

M29940A

Fig. 3. Wiring to force the HVAC system fan on whenever humidity is needed (on demand).

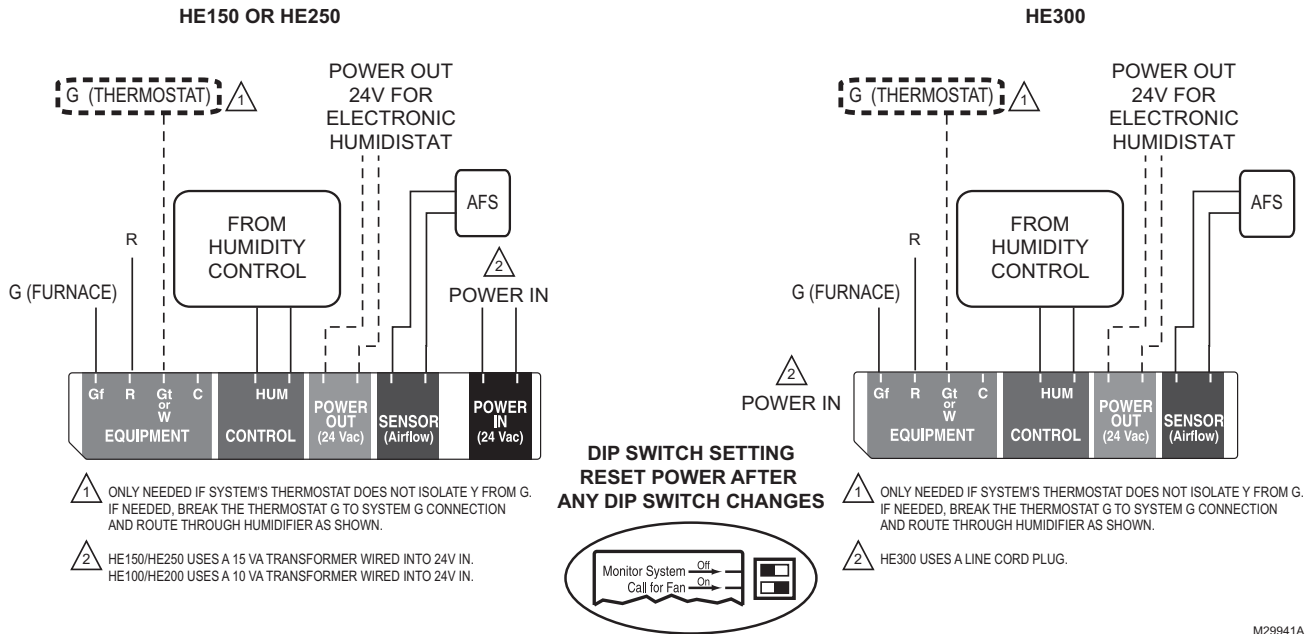

M29941A

Fig. 4. Wiring to force fan on and prove airflow in the duct.

BASIC MODELS (HE100/HE200)

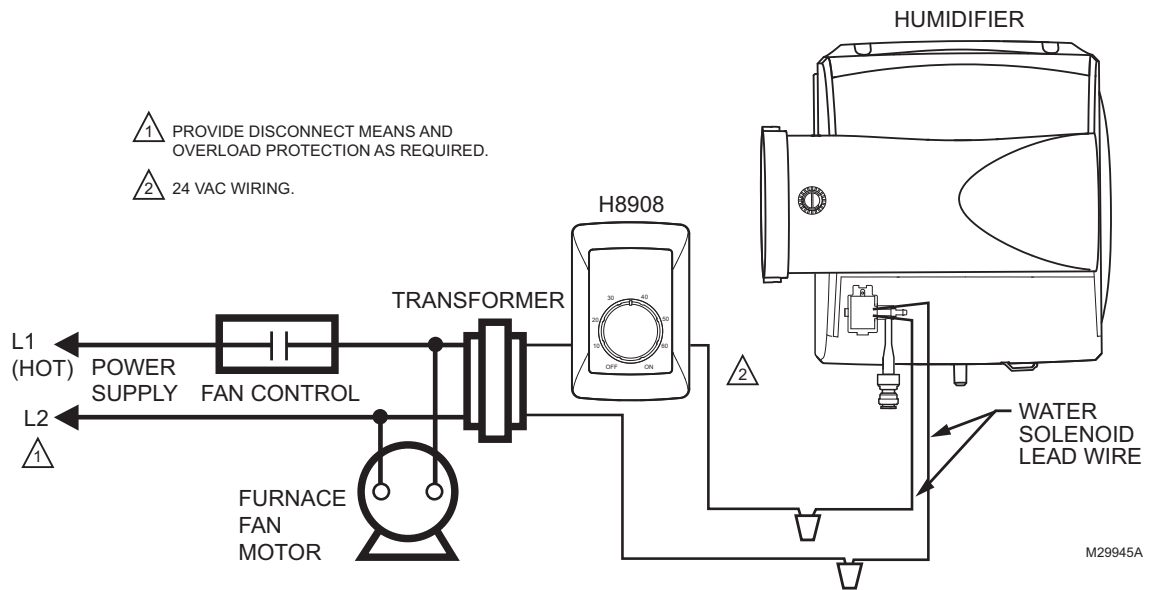

Fig. 5. Wiring H8908 with fan interlock.

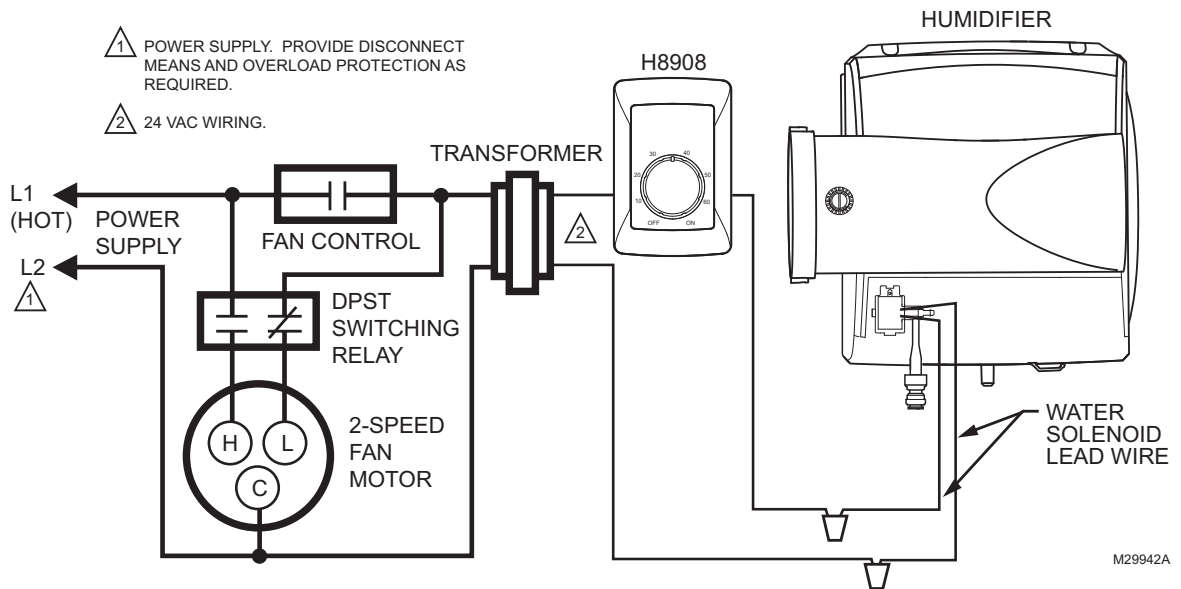

Fig. 6. Wiring H8908 with 2-speed fan motor.

WIRING CONFIGURATION

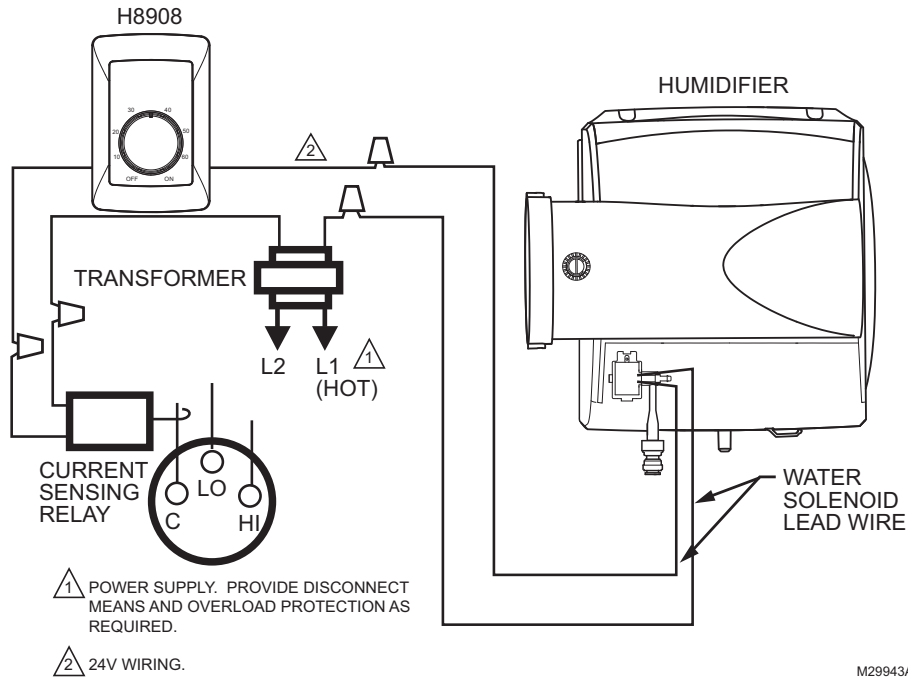

Fig. 7. Wiring H8908 with current-sensing relay.

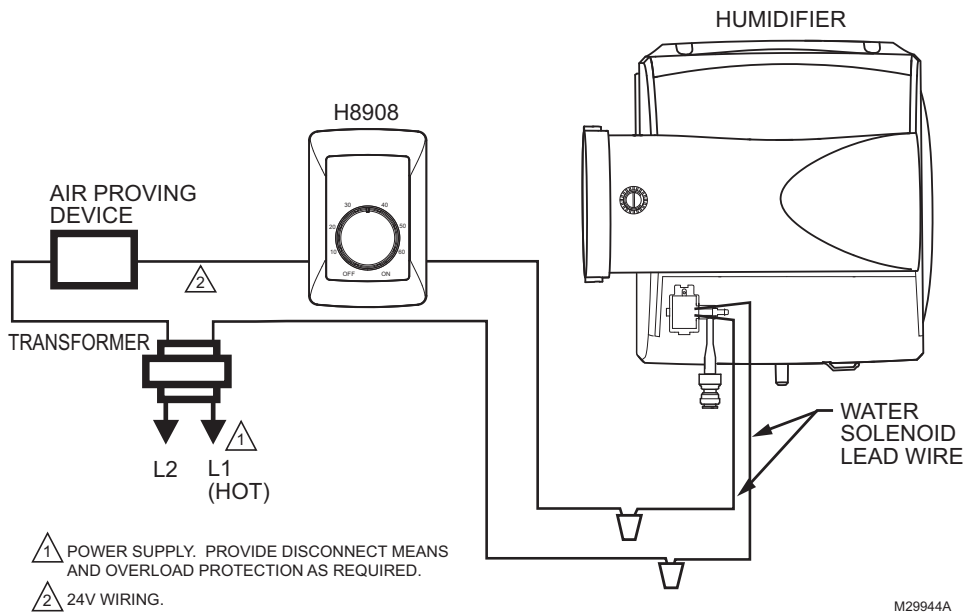

Fig. 8. Wiring H8908 in line with air proving device.

Automation and Control Solutions

Honeywell International Inc.
 1985 Douglas Drive North
 Golden Valley, MN 55422

Honeywell Limited-Honeywell Limitée
 35 Dynamic Drive
 Toronto, Ontario M1V 4Z9
 customer.honeywell.com

© U.S. Registered Trademark
 © 2011 Honeywell International Inc.
 69-2576-01 M.S. 01-11
 Printed in U.S.A.

Honeywell