

### Installation and Setup Guide

#### GENERAL INFORMATION

The ADEMCO 6160RF keypad/transceiver is a combination unit that combines the functions of the following devices:

- 6160 Alphanumeric Addressable Keypad
- 5881H RF Receiver
- 5800TM Transmitter Module

The 6160RF Keypad/Transceiver may be used on any control panel that supports 5800 Series wireless devices (e.g., VISTA-10P, VISTA-15P, VISTA-20P).

#### FEATURES

- Supports wireless key transmitters (e.g.; 5804) and bi-directional transmitters (e.g.; 5804BD, 5828/5828V).
- Supports wireless keys with high-security (encryption) capability (e.g.; 5804E).
- Provides a nominal range of 200 feet' for RF transmitters (some transmitters have a shorter range).
- Supports RF jam detection when the receiver is enabled.
- Capable of sending status signals (Armed, Ready, etc.) to bi-directional units such as 5804BD, 5804BDV and 5828/5828V.

**UL** The following 5800 series transmitters are not intended for use in UL installations: 5802, 5804, 5804BD, 5804BDV, 5804E, 5814, 5816TEMP, 5819, 5819BRS, 5819WHS, 5828/5828V and 5850.

#### INSTALLING THE 6160RF

Locate the 6160RF in an area and at a height where it is convenient for user operation. The 6160RF must be at least 10 ft from the control panel to ensure proper operation of the RF receiver.

##### Mounting and Wiring

The 6160RF has terminal blocks for connection to power and data wires. Removing the keypad's case back provides access to the terminal blocks.

The 6160RF can be surface mounted directly to walls, or to a single- or double-gang electrical box. Follow these steps to mount and wire the keypad:

1. Push the two case release snaps at the bottom of the keypad with the blade of a medium screwdriver (this will push in the release snap), then pull that side of the case back away. Insert the screwdriver in the side of the keypad (between the front and back case) and gently twist to release the side locking tab. Repeat for the other side. Refer to Figure 1 for location of the case back release snaps and locking tabs.

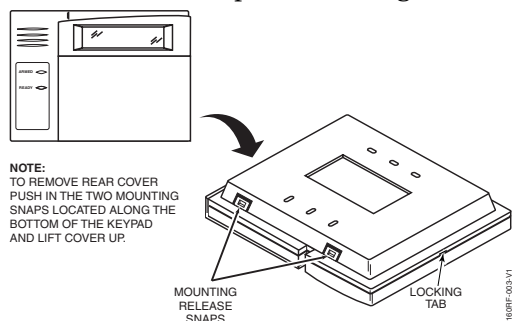

Figure 1. Removing the Case Back

2. Pass the wiring from the control panel through the opening in the case back. (see the control panel's instructions for proper run lengths.)
  - a. If surface wiring is being used, wiring may be routed through the top or the bottom left-side breakout in the case back. The breakouts must be punched out using a screwdriver before mounting the case back.
  - b. If desired, wires may be strain-relieved to the wire tie point on the inside of the case back with a tie wrap (not supplied).
3. Mount the case back to a wall or to an electrical box using the 25mm-long self-tapping screws supplied (mollies for drywall are not supplied).
4. Connect the power and data wires from the control panel to the terminals on the 6160RF as indicated in Figure 2 and Table 1.

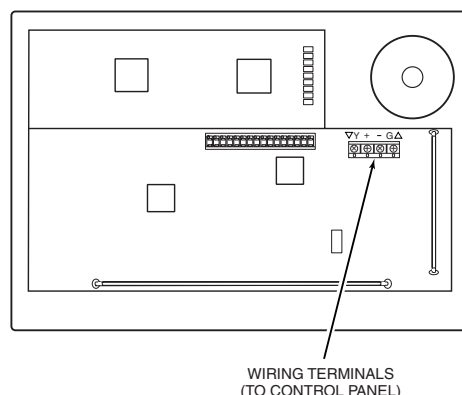

Figure 2 - 6160RF Wiring Details

**Table 1 - Wiring Table**

Keypad	Control Panel	Wire Color
G▼ (Data Out)	Data In	Green
-	-Aux Pwr (GND)	Black
+	+Aux Pwr	Red
▲Y (Data In)	Data Out	Yellow

- Reattach the keypad to the mounted case back. Attach the top of the keypad first, and then press the bottom section down until it snaps into place securely.
- Peel off protective film on the LED panel and install the keypad labels as required.

## APPLICATION GUIDELINES FOR THE 6160RF

Use the following guidelines when planning an installation:

If...	And...	Then...
This is the only transceiver on the system,	You want to use both the receiver and transmitter function on a single-partition system,	<ul style="list-style-type: none"> <li>Set the keypad to a device address assigned to the desired partition.*</li> <li>Enable the receiver.</li> <li>Program a system House ID in the control panel (this will enable the transmitter function).**</li> <li>Set the wireless devices that will communicate with this 6160RF to the same system House ID.</li> </ul>
There is another receiver or transceiver on the system,	You want to use only the transmitter function on a second partition,	<ul style="list-style-type: none"> <li>Set the keypad to a device address assigned to the desired partition.*</li> <li>Disable the receiver.</li> <li>Program a DIFFERENT House ID in the 6160RF than is programmed in the control panel.*/**</li> <li>Set the wireless devices that will communicate with this 6160RF to the same House ID as the 6160RF.</li> </ul>
	You want to use only the transmitter function on a single-partition system,	<ul style="list-style-type: none"> <li>Set the keypad to a device address assigned to the Partition 1.</li> <li>Disable the receiver.</li> <li>Program a House ID in the 6160RF that matches the system House ID programmed in the control panel.*</li> <li>Set the wireless devices that will communicate with this 6160RF to the same House ID.</li> </ul>

### Notes:

\* On VISTA-40 panels and above, wireless keypads (e.g., 5804BD) can only be used on a single partition. This partition is programmed in field 1\*48, and must match the partition assigned to the 6160RF. Wireless keys can be used on more than one partition, using a House ID programmed in the 6160RF and the devices. In this case, the wireless keys must be assigned to the same partition as the 6160RF.

\*\* On VISTA-20P panels, the 6160RF will use the House ID programmed in the panel for the partition to which it is assigned. Wireless keypads can only be used on Partition 1.

## PROGRAMMING THE 6160RF

Refer to the following procedure to program the 6160RF:

STEP	DESCRIPTION	DISPLAY	CHOICES
1.	Enter the program mode by pressing the [1] and [3] keys simultaneously for a few seconds within 60 seconds after applying power.		
2.	(Keypad Address) Enter the two-digit keypad address. Press the [*] key to continue. <b>Notes: (1) Refer to the control panel's installation instructions for the acceptable keypad addresses. (2) On the VISTA-40 and above the 6160RF's partition assignment must match the RF keypad partition assignment programmed in field (1*48).</b>	<b>CONADDRESS = XX</b>	00-31
3.	(Receiver Enable) Enter [1] to enable, or [0] to disable Receiver. Enable the receiver if RF transmitters or wireless keypads are programmed into the control and no other receivers are enabled. Press the [*] key to continue.	<b>RECEIVER ON [0 = OFF]</b>	1 = ON 0 = OFF

STEP	DESCRIPTION	DISPLAY	CHOICES
4.	(Receiver Address) If receiver is enabled, enter the two-digit receiver address. (01-30). <b>Note: Refer to the control panel's installation instructions for the acceptable receiver addresses.</b> Press the [*] key to continue.	<i>REC ADDRESS = XX</i>	00-30
5.	(House ID) This prompt will only appear if the receiver is disabled. If the receiver is enabled the 6160RF will use the House ID programmed in the panel. Refer to Application Guidelines section when selecting a House ID. To program a House ID: Enter 01-31. To disable the transmitter: Enter 00 <b>Note: Each device that will receive status from the 6160RF must be set to the same House ID as the 6160RF (refer to Application Guidelines section).</b> Press the [*] key to continue.	<i>HOUSE ID = XX</i>	00-31
6.	(Enable High Security Mode) Enter [1] to select High Security Mode. <b>Note: If the High Security mode is enabled, the 6160RF will only recognize encrypted devices. If this mode is disabled, the 6160RF will process commands both encrypted and non-encrypted devices. *</b> Press the [*] key to continue.	<i>HIGH SECURITY OFF [1] = ON</i>	1 = Enable 0 = Disable
7.	(Disable High Security Devices) Press the [*] key to skip this prompt and exit Program Mode. <b>Notes: (1) The [*] key must be pressed several times in order to save the programmed data. (2) If you need to disable encrypted devices, refer to the Disabling High Security Devices section.</b>	<i>DISABLE HS DEVP NO [1] = YES</i>	1 = YES 0 = NO



\* When operating the system in High-Security mode, 5804BD wireless keys will still function. If you want the system to recognize only encrypted wireless devices, program only encrypted devices in the system.

### ACTIVATING HIGH SECURITY DEVICES

This following procedure should be followed if using High-Security (encrypted) devices.

STEP	DESCRIPTION
1.	Follow the normal procedure for programming the device into the control panel (refer to the Installation Instructions for the device that you are programming). Exit out of Programming Mode.
2.	Put the control panel in Go/ No Go Test mode. (See the Installation Guide for the panel being installed.)
3.	Follow the instructions supplied with each wireless device to enroll the device in High-security mode. After each device is enrolled the 6160RF will momentarily display "SECURITY DEVICE" along with the device number and its serial number. <b>Note: The 6160RF will support a maximum of 8 devices. If you attempt to enroll additional devices the keypad will display "EXCEEDED NUMBER" "ALLOWED DEVICES".</b>

### DISABLING HIGH SECURITY DEVICES

This mode gives you the ability to disable high security on all wireless keys that have been enrolled in the 6160RF. This is particularly useful if a user loses a wireless key.



Once high-security (encrypted) devices have been disabled, they will only operate if the 6160RF is set to listen to both encrypted and non-encrypted devices (programming step 6, above). To completely disable the devices, they must be deleted from the control panel.

STEP	DESCRIPTION	DISPLAY	CHOICES
1.	After the keypad has been powered for at least 60 seconds hold down the [1] and [3] keys at the same time for 3 seconds. The current keypad address will be displayed. (You cannot change the keypad's address at this point.) Press the [*] key to continue.	<i>CON ADDRESS = XX</i>	00-31
2.	(Delete High Security Devices) Press the [1] key to remove all high-security (encrypted) devices. Press the [*] key to continue.	<i>DISABLE HS DEVP NO [1] = YES</i>	1 = YES 0 = NO
3.	If YES was selected in Step 2 the unit will display a confirm request to delete the stored high security device. Press the [1] key to accept, followed by the [*] key to exit the programming mode.	<i>ARE YOU SURE? NO [1] = YES</i>	1 = YES 0 = NO

## TROUBLESHOOTING

The error messages listed in the following table cause the 6160RF to produce a single ding tone. The table describes the error messages and the corrective actions.

Display	Probable Cause	Corrective Action
<b>Low Bat (with zone no.)</b>	Low battery in the wireless device.	1. Replace the battery if the wireless transmitter has a replaceable battery. 2. Replace the transmitter if the wireless transmitter does not have a replaceable battery.
<b>Open Ckt</b>	No data is being received from the control panel.	Verify that the keypad ▲Y (yellow) wire is connected properly.
<b>Check 100</b> <b>Check 1xx*</b>	1. The control panel does not see the 6160RF Receiver, or the Receiver is not functioning.  2. Another device on the keypad terminals is not communicating to the control panel.	1a. Verify that the keypad ▲Y (yellow) and G▼ (green) wires are connected properly. 1b. Verify that the control's receiver address is correct. 2. Verify the wiring connections between the control and all other devices.

\*xx= the device address of the receiver.

## SPECIFICATIONS

<b>Physical:</b>	5-3/8" H x 7-3/8" W x 1-1/4" D (137mm x 187mm x 32mm)	<b>Current:</b>	Standby 50mA Backlighting on and Sounder on 150mA
<b>Wiring:</b>	Refer to Table 1	<b>Display:</b>	2 x 16 alphanumeric supertwist LCD, backlit
<b>Range:</b>	200 ft (60.9 m) nominal	<b>Sounder:</b>	Tone Generator Integrated Circuit. (fire alarm is loud pulsing tone; burglary/audible panic alarm is continuous tone)
<b>Frequency:</b>	345 MHz		

FOR DETAILS ON THE LIMITATIONS OF THE ENTIRE ALARM SYSTEM, REFER TO THE INSTALLATION AND SETUP GUIDE FOR THE CONTROL PANEL BEING INSTALLED IN CONJUNCTION WITH THIS DEVICE.

### FCC STATEMENT & INDUSTRY CANADA STATEMENT

This device complies with Part 15 of the FCC rules and RSS210 of Industry Canada. Operation is subject to the following two conditions: (1) This device may not cause harmful interference, and (2) This device must accept any interference received, including interference that may cause undesired operation.

### Federal Communications Commission (FCC) Part 15 Statement

This equipment has been tested to FCC requirements and has been found acceptable for use. The FCC requires the following statement for your information:

This equipment generates and uses radio frequency energy and if not installed and used properly, that is, in strict accordance with the manufacturer's instructions, may cause interference to radio and television reception. It has been type tested and found to comply with the limits for a Class B computing device in accordance with the specifications in Part 15 of FCC Rules, which are designed to provide reasonable protection against such interference in a residential installation. However, there is no guarantee that interference will not occur in a particular installation. If this equipment does cause interference to radio or television reception, which can be determined by turning the equipment off and on, the user is encouraged to try to correct the interference by one or more of the following measures:

- If using an indoor antenna, have a quality outdoor antenna installed.
- Reorient the receiving antenna until interference is reduced or eliminated.
- Move the radio or television receiver away from the receiver/control.
- Move the antenna leads away from any wire runs to the receiver/control.
- Plug the receiver/control into a different outlet so that it and the radio or television receiver are on different branch circuits

If necessary, the user should consult the dealer or an experienced radio/television technician for additional suggestions. The user or installer may find the following booklet prepared by the Federal Communications Commission helpful: "Interference Handbook." This booklet is available from the U.S. Government Printing Office, Washington, DC 20402.

The user shall not make any changes or modifications to the equipment unless authorized by the Installation Instructions or User's Manual. Unauthorized changes or modifications could void the user's authority to operate the equipment.

### LIMITED WARRANTY

Honeywell International Inc., acting through its Security & Custom Electronics business ("Seller") 165 Eileen Way, Syosset, New York 11791, warrants its products to be in conformance with its own plans and specifications and to be free from defects in materials and workmanship under normal use and service for 24 months from the date stamp control on the product or, for products not having an Ademco date stamp, for 12 months from date of original purchase unless the installation instructions or catalog sets forth a shorter period, in which case the shorter period shall apply. Seller's obligation shall be limited to repairing or replacing, at its option, free of charge for materials or labor, any product which is proved not in compliance with Seller's specifications or proves defective in materials or workmanship under normal use and service. Seller shall have no obligation under this Limited Warranty or otherwise if the product is altered or improperly repaired or serviced by anyone other than Ademco factory service. For warranty service, return product transportation prepaid, to Factory Service, 165 Eileen Way, Syosset, New York 11791.

THERE ARE NO WARRANTIES, EXPRESS OR IMPLIED, OF MERCHANTABILITY, OR FITNESS FOR A PARTICULAR PURPOSE OR OTHERWISE, WHICH EXTEND BEYOND THE DESCRIPTION ON THE FACE HEREOF. IN NO CASE SHALL SELLER BE LIABLE TO ANYONE FOR ANY CONSEQUENTIAL OR INCIDENTAL DAMAGES FOR BREACH OF THIS OR ANY OTHER WARRANTY, EXPRESS OR IMPLIED, OR UPON ANY OTHER BASIS OF LIABILITY WHATSOEVER, EVEN IF THE LOSS OR DAMAGE IS CAUSED BY THE SELLER'S OWN NEGLIGENCE OR FAULT.

Seller does not represent that the products it sells may not be compromised or circumvented; that the products will prevent any personal injury or property loss by burglary, robbery, fire or otherwise; or that the products will in all cases provide adequate warning or protection. Customer understands that a properly installed and maintained alarm may only reduce the risk of a burglary, robbery, fire or other events occurring without providing an alarm, but it is not insurance or a guarantee that such will not occur or that there will be no personal injury or property loss as a result. CONSEQUENTLY, SELLER SHALL HAVE NO LIABILITY FOR ANY PERSONAL INJURY, PROPERTY DAMAGE OR OTHER LOSS BASED ON A CLAIM THE PRODUCT FAILED TO GIVE WARNING. HOWEVER, IF SELLER IS HELD LIABLE, WHETHER DIRECTLY OR INDIRECTLY, FOR ANY LOSS OR DAMAGE ARISING UNDER THIS LIMITED WARRANTY OR OTHERWISE, REGARDLESS OF CAUSE OR ORIGIN, SELLER'S MAXIMUM LIABILITY SHALL NOT IN ANY CASE EXCEED THE PURCHASE PRICE OF THE PRODUCT, WHICH SHALL BE THE COMPLETE AND EXCLUSIVE REMEDY AGAINST SELLER. This warranty replaces any previous warranties and is the only warranty made by Seller on this product. No increase or alteration, written or verbal, of the obligations of this Limited Warranty is authorized.



K0903V1 2/06 Rev. B

**Honeywell**

165 Eileen Way, Syosset, New York 11791  
Copyright © 2006 Honeywell International Inc.

www.honeywell.com/security