

## T8190A/191108AJ Heating or Cooling Thermostat/Wallplate; T8190A/Q682B Heating/Cooling Thermostat/Subbase

Installation Instructions for the Trained Service Technician.

### Preparation

Check thermostat and subbase (if used) suitability for the heating, cooling, or heating/cooling system. Refer to Table 1.

Assemble tools required: flat-bladed screwdriver, hand or power drill with 3/16-in. drill bit, wire cutter/stripper or sharp knife, bubble level or plumb bob and line.

Assure power is off to the heating, cooling, or heating/cooling system at the main fuse panel. Most buildings have a separate switch box or circuit breaker for disconnecting power to the heating and cooling (if applicable) equipment.

This thermostat is compatible with all heating, cooling or heating/cooling systems when thermostat is powered by batteries. If thermostat is not powered by batteries, refer to Table 1 for thermostat and system compatibility information.

NOTE: Order Q682B Subbase separately.



### Recycling Notice

This control contains mercury in a sealed tube. Do *not* place control in the trash at the end of its useful life.

If this control is replacing a control that contains mercury in a sealed tube, do *not* place your old control in the trash.

Contact your local waste management authority for instructions regarding recycling and the proper disposal of this control, or of an old control containing mercury in a sealed tube.

If you have questions, call Honeywell Inc. at 1-800-468-1502.

TABLE 1—SYSTEM COMPATIBILITY FOR NON-BATTERY POWERED THERMOSTATS.

| Type of Heating System to be Controlled                                           | Conditions/Compatibility                                                                                                                                                                                                                                                                                                                    |
|-----------------------------------------------------------------------------------|---------------------------------------------------------------------------------------------------------------------------------------------------------------------------------------------------------------------------------------------------------------------------------------------------------------------------------------------|
| Electric (Line Voltage)—typical baseboard and radiant                             | <ul style="list-style-type: none"> <li>The R8239D1015 Isolating Relay or R841 Silent Switching Center must be installed in the thermostat control circuit.<sup>a</sup></li> </ul>                                                                                                                                                           |
| Fan Coil Unit                                                                     | <ul style="list-style-type: none"> <li>Compatible. Assure correct subbase identity is selected for fan control.</li> </ul>                                                                                                                                                                                                                  |
| Gas—Direct Spark Ignition (DSI), Intermittent Pilot (IP), and Standing Pilot (SP) | <ul style="list-style-type: none"> <li>Compatible. If not using battery backup, assure that 24V control transformer common is accessible for connection to thermostat cable conductor and power to the transformer is not regularly interrupted by high temperature or limit operation.</li> </ul>                                          |
| Heat Pump                                                                         | <ul style="list-style-type: none"> <li>Compatible. Assure correct subbase identity is selected for fan control and changeover control (O terminal for cool and B terminal for heat).</li> </ul>                                                                                                                                             |
| Hot Water Zone                                                                    | <ul style="list-style-type: none"> <li>Honeywell 2-wire valves are compatible.</li> <li>Some non-Honeywell 2-wire valves require an R8239D1015 Isolating Relay in the thermostat control circuit.<sup>a</sup></li> <li>Some 3-wire valves require an R8239A1052 Isolating Relay in the thermostat control circuit.<sup>a,b</sup></li> </ul> |
| Oil                                                                               | <ul style="list-style-type: none"> <li>If not using battery backup, assure that the 24V control transformer common is accessible for connection to thermostat cable conductor and power to the transformer is not regularly interrupted by high temperature, purge cycle, or limit operation.</li> </ul>                                    |
| Vent Damper                                                                       | <ul style="list-style-type: none"> <li>Honeywell damper motors are compatible.</li> <li>Some non-Honeywell damper motors require an R8239D1015 Isolating Relay in the thermostat control circuit.<sup>a</sup> Check control amperage requirement.</li> </ul>                                                                                |
| Warm Air Zone                                                                     | <ul style="list-style-type: none"> <li>Most are compatible.</li> </ul>                                                                                                                                                                                                                                                                      |

<sup>a</sup> If thermostat is not compatible with the system being controlled, the system will not operate. No hazard exists. The thermostat will not be damaged unless it is used to directly control a line voltage system. For proper system operation, a Honeywell R841 or R8239D1015 Isolating Relay must be added to the thermostat control circuit.

<sup>b</sup> Consult manufacturer for installation requirements.

# Installation

## WHEN INSTALLING THIS PRODUCT...

1. Read these instructions carefully. Failure to follow them could cause a hazardous condition.
2. Installer must be a trained experienced service technician.
3. After installation is complete, check out product operation as provided in these instructions.

**IMPORTANT:** An incorrectly leveled subbase will cause the temperature control to deviate from setpoint. It is not a calibration problem.



## CAUTION

1. Disconnect power supply to prevent electrical shock or equipment damage.
2. To prevent interference with the thermostat linkage, keep wire length to a minimum and run wires as close as possible to the subbase.
3. Do not overtighten thermostat captive mounting screws because damage to subbase threads can result.
4. Do not short across coil terminals on relay. This can burn out the thermostat heat anticipator.

## LOCATION

Locate thermostat about 5 ft [1.5m] above the floor in an area with good air circulation at average temperature.

Do not mount the thermostat where it may be affected by:

- drafts, or dead spots behind doors and in corners.
- hot or cold air from ducts.
- radiant heat from the sun or appliances.
- concealed pipes and chimneys.
- unheated (uncooled) areas such as an outside wall behind the thermostat.

Run wires from the heating, cooling or heating/cooling equipment to the new thermostat location.

Refer to the Typical Wiring Diagrams section to determine the number of wires required for your application.

## UNPACK THERMOSTAT

Handle your new thermostat carefully; rough handling may interfere with its accuracy. Before unpacking, refer to Fig. 1.

Remove and discard the shipping wrap.

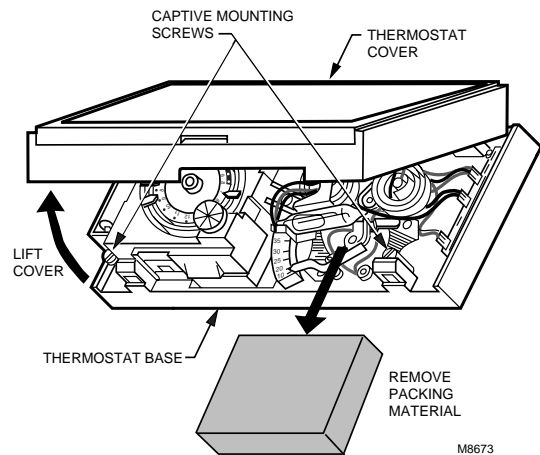
**IMPORTANT:** Save package of screws and instructions for the homeowner.

Remove the thermostat cover by lifting from the bottom. Set aside cover until needed later.

Carefully remove the material protecting the mercury switch bulb.

Loosen two captive mounting screws and separate wallplate (if provided) from back of thermostat base.

Fig. 1—Unpack thermostat.



## MOUNT WALLPLATE OR SUBBASE

### Wall Mounting (Fig. 2)

Hold the wallplate or subbase in position on wall (Fig. 2).

Mark holes on the wall for anchors. Use spirit level to make sure the wallplate or subbase is level.

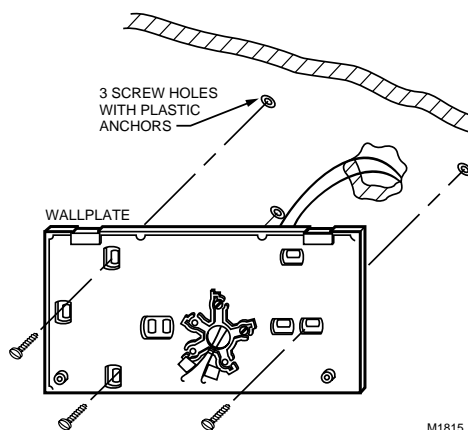
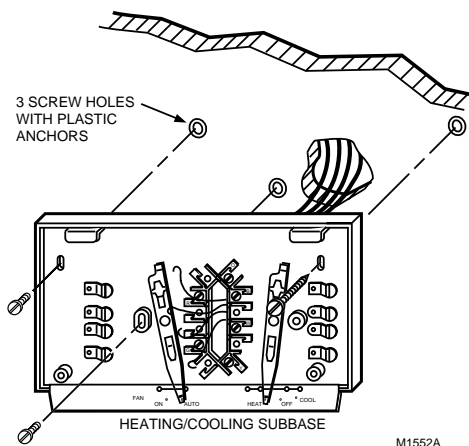
Drill 3/16-in. holes, and gently tap anchors into holes until flush with the wall.

Pull wires through the large wiring hole in the wallplate or subbase.

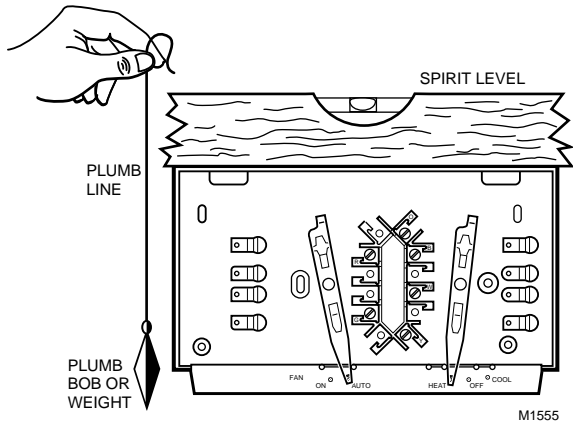
Loosely fasten the wallplate or subbase to the wall with the three screws. Do not completely tighten the screws.

Carefully level the wallplate or subbase (Fig. 3), and firmly tighten the screws.

Fig. 2—Mounting wallplate or subbase to wall.



**Fig. 3—Leveling methods for wallplate or subbase.**



**Outlet Box Mounting (Fig. 4)**

Use a horizontally mounted outlet box if possible. If a vertical outlet box is used, mount the wallplate or subbase on a 193121A (beige) Cover Plate Assembly (ordered separately). Follow the instructions provided with the cover plate assembly.

Align the wallplate or subbase mounting holes on the outlet box and loosely fasten with two screws.

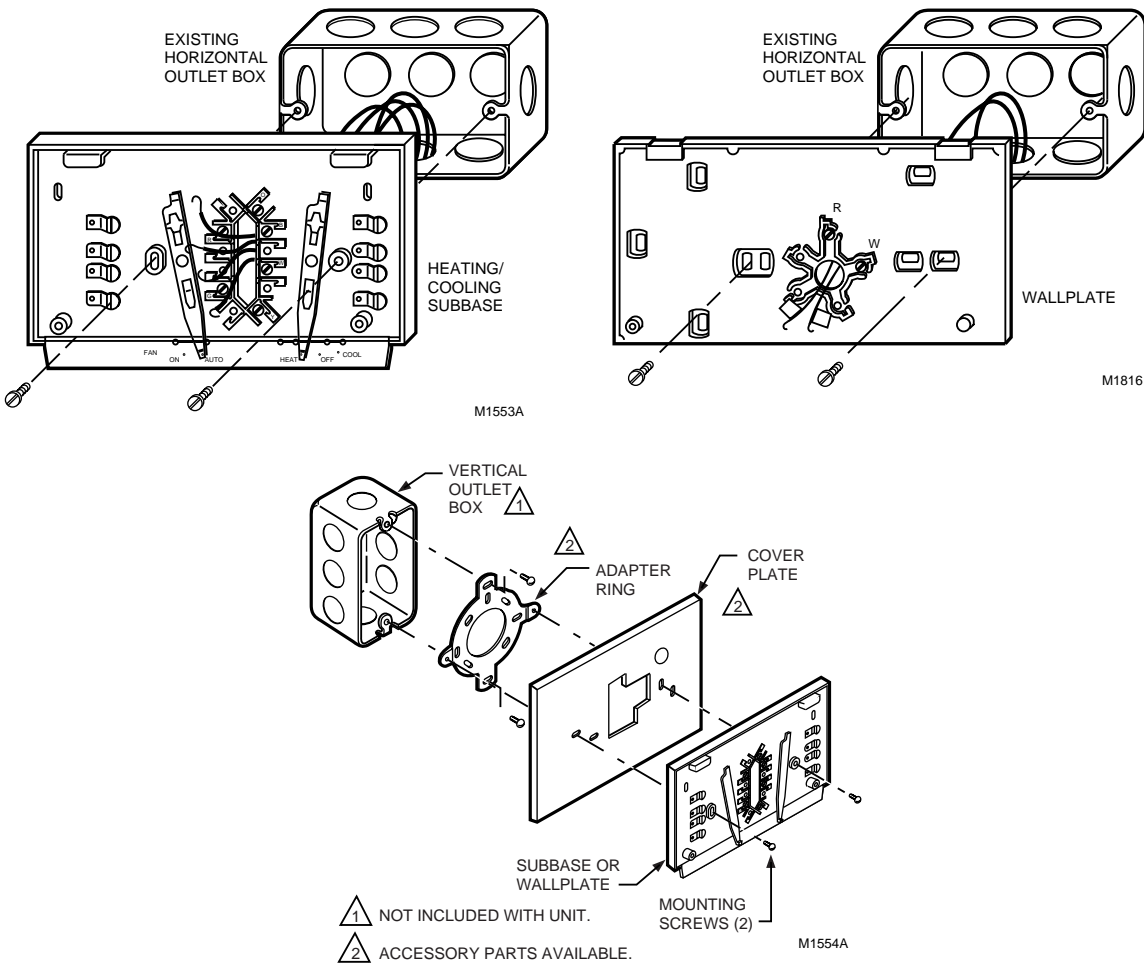
Carefully level the wallplate or subbase (Fig. 3), and firmly tighten the screws.

**WIRE WALLPLATE OR SUBBASE**

Follow the instructions provided by the heating, cooling, or heating/cooling equipment manufacturer. If not available, refer to the Typical Wiring Diagrams section at the end of this publication.

Disconnect the power supply before making wiring connections to prevent electrical shock or equipment damage.

**Fig. 4—Mounting wallplate or subbase on horizontal outlet box.**



**NOTE:** All wiring must comply with local electrical codes and ordinances.

This thermostat clock can be powered by a 24 Vac transformer with battery backup. Refer to Figs. 15 through 19 for hookup diagrams of typical powering applications.

**For Wallplate (Heating or Cooling Systems)**

Refer to Fig. 5 and strip the thermostat wire insulation as necessary.

For heating-only systems, connect wires to R, W, and C (if applicable) terminals (Fig. 20). For cooling-only systems, connect wires R, Y, and C (if applicable) terminals. Firmly tighten the screws.

Push excess wire back into the wall.

Plug the hole in the wall with nonhardening caulk, putty, or nonflammable insulation to prevent drafts from affecting thermostat operation.

**Subbase (Heating/Cooling Systems)**

Refer to Fig. 5 and strip the thermostat wire insulation as necessary.

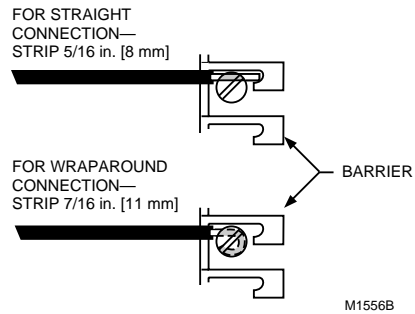
Connect the wires to the corresponding terminals on the subbase. If labels do not agree with your new subbase, refer to Table 2 and the installation instructions furnished with the subbase.

NOTE: If wiring a dual transformer system, only the O or the B terminal may be used.

Push excess wire back into the wall.

Plug the hole in wall with nonhardening caulk, putty, or nonflammable insulation to prevent drafts from affecting the thermostat operation.

**Fig. 5—Methods of connecting terminals.**



**TABLE 2—SUBBASE TERMINAL DESIGNATIONS.**

| Subbase Terminal | Control Function                                                                                   |
|------------------|----------------------------------------------------------------------------------------------------|
| R                | Control transformer power.                                                                         |
| R <sub>c</sub>   | Line side of 24V power supply; cooling side, 2 transformer heat/cool system.                       |
| R <sub>h</sub>   | Line side of 24V power supply; heating side, 2 transformer heat/cool system.                       |
| W                | Heating control circuit.                                                                           |
| Y                | Cooling control circuit; jumper to W for heat pump compressor control if no P terminal on subbase. |
| G                | Fan control circuit.                                                                               |
| C                | Clock control (transformer common).                                                                |
| O                | Cooling damper or changeover/reversing valve, makes continuously in cool.                          |
| B                | Heating damper or changeover/reversing valve, makes continuously in heat.                          |
| P                | Heat pump contactor; P terminal on some models only.                                               |

**MOUNT THE THERMOSTAT**

Note the tabs on the top inside edge of the thermostat base. These tabs fit the slots molded into the top of the wallplate or subbase.

Hang the thermostat base on the wallplate or subbase.

Insert the two captive mounting screws located in the bottom corners of the base (Fig. 6).

Firmly tighten the screws.

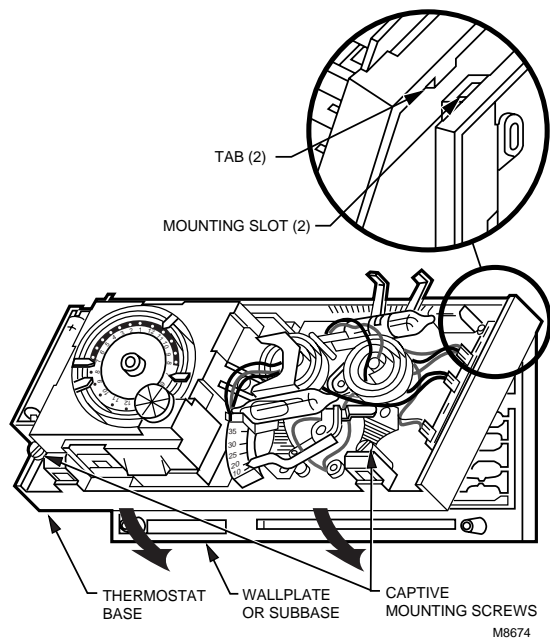
**INSERT TIMER BATTERIES**

Power is supplied to the clock by the 24 Vac transformer or two AAA alkaline batteries (included), or by the heating or cooling control circuit. Backup batteries may be installed to supply power to the clock if power is interrupted when using 24 Vac powering method.

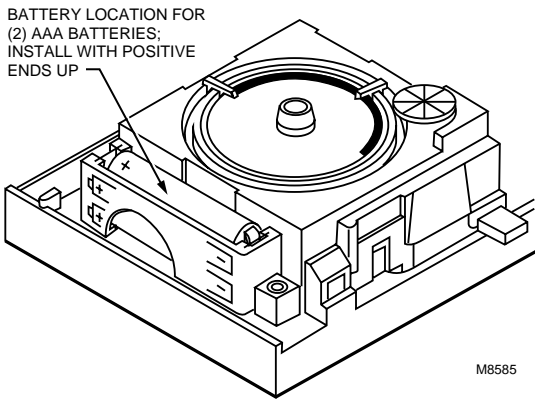
Install the batteries in the thermostat (Fig. 7).

Once a year or when batteries are dead, replace with two new AAA alkaline batteries. Properly dispose of old batteries. We recommend Energizer® batteries.

**Fig. 6—Thermostat mounting.**



**Fig. 7—Insert timer batteries.**



**SET TIMER**

Adjust the timer by moving the knob clockwise ↻. Do *not* reverse the knob.

When time is correctly set, the time indicator arrow (triangle shape) points to the correct time and the corresponding daytime (light) or nighttime (dark) portion of the program dial (Fig. 8).

**SET HEAT ANTICIPATOR**

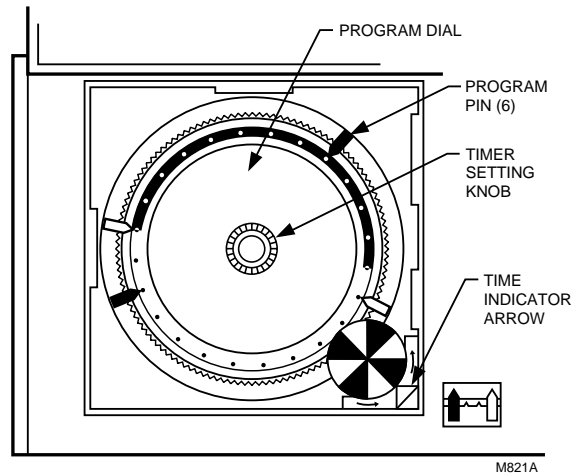
Adjust the heat anticipator lever to match the current rating of the primary control for the proper cycle rate (Fig. 9). Adjustable anticipation must be set for total current of heat and fan control.

The current rating is usually stamped on the control or valve (Fig. 10), or a setting may be given in the device instructions.

If no current rating or heat anticipator setting is given, measure the current with an ammeter. Proceed with the following steps.

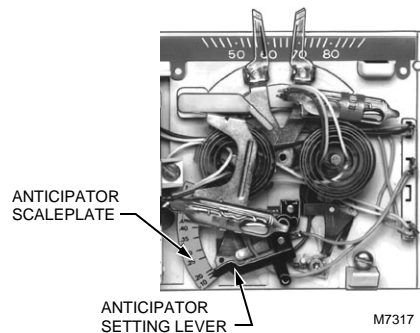
Remove the thermostat from the wallplate or subbase. Connect an ac ammeter of appropriate range (about 0A to 2A) between the R and W terminals on the wallplate or subbase, except for electric heat and heat pump systems.

**Fig. 8—Set timer.**

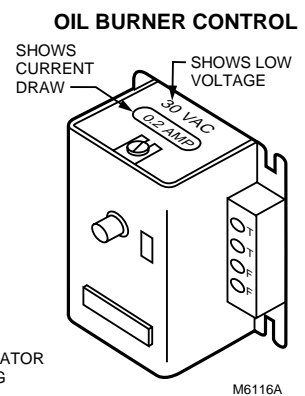
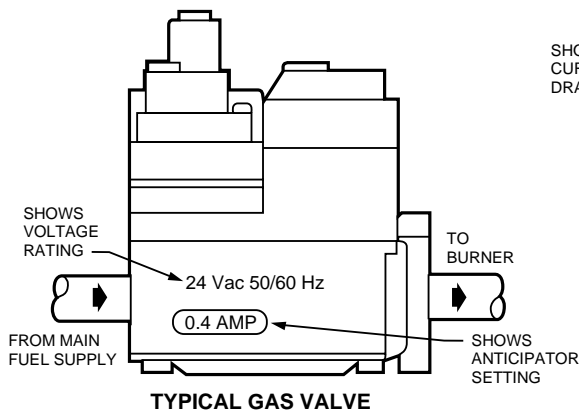
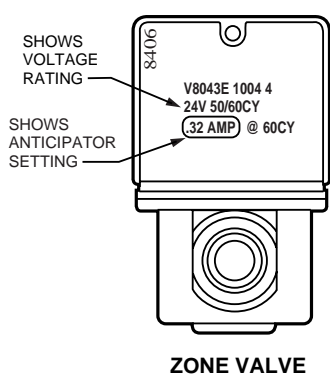


Let the system operate for one minute. Adjust the heat anticipator lever to match the number that reads on the ammeter.

**Fig. 9—Adjust heat anticipator.**



**Fig. 10—Current rating of primary control.**



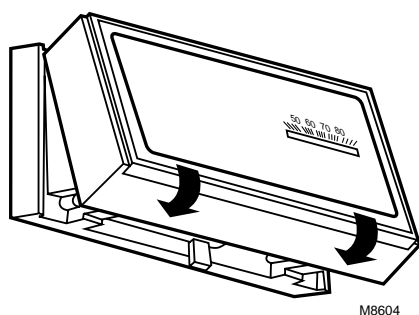
### ATTACH THERMOSTAT COVER

Make sure the packing inserts in the thermostat base are removed.

Place the two tabs on the upper edge of the cover into the mounting slots in the thermostat base (Fig. 11).

Swing the cover downward until it catches at the bottom of the base.

Fig. 11—Attach cover.

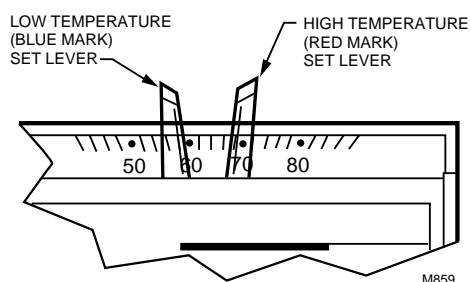


### SET TEMPERATURE CONTROL LEVERS

The two levers on the top of the thermostat control the low and high temperatures for energy savings and comfort control (Fig. 12). The lever on the left (blue mark) controls the lower temperature. The lever on the right (red mark) controls the higher temperature.

We recommend pushing the levers together at an appropriate temperature for either heat or cool until the occupant programs the thermostat and makes the final temperature selections.

Fig. 12—Temperature control levers.



### SET SUBBASE SWITCHES (IF APPLICABLE)

The subbase system switch controls system operation as follows:

**HEAT:** Heating system is controlled by the thermostat. Cooling system is off.

**COOL:** Cooling system is controlled by the thermostat. Heating system is off.

**OFF:** Both the heating and cooling systems are off. If the fan switch is in the AUTO position, the fan is also off. The subbase fan switch controls fan operation as follows:

**ON:** Fan operates continuously.

**AUTO:** Fan operates with the cooling equipment as controlled by the thermostat or with the heating equipment as controlled by the plenum switch. In electric heat, heat pump, and fan coil systems, the fan is controlled by the thermostat in heating and cooling.

To switch positions, use thumb or index finger to slide lever to the desired position. Switch lever must stop in detent over the desired function indicator mark for proper circuit operation.

## Checkout



### CAUTION

Do *not* check operation by shorting across the terminals of the system controls. This will damage the heat anticipator.

### HEATING-ONLY SYSTEM

Turn on power to the furnace.

Push both temperature setting levers together at least 5° F [3° C] above the room temperature. The main burner should come on. The fan will start when the furnace heats up.

Move both levers 5° F [3° C] below the room temperature. The burner should shut off.

Operate the entire heating system at least one complete cycle.

If thermostat fails any test, refer to the Troubleshooting Guide in the Owner's Manual.

Reset both temperature setting levers to the desired temperatures.

### COOLING-ONLY SYSTEM

Turn on power to the cooling equipment.

Push both temperature setting levers together at least 5° F [3° C] below the room temperature. The cooling equipment will operate, and the fan will start. Allow for any time delay that may be built into the compressor control circuit.

**NOTE:** To avoid compressor damage, do not operate the system when outdoor temperature is below 50° F [10° C]. Refer to manufacturer recommendations.

Move both levers 5° F [3° C] above room temperature. The cooling equipment and the fan should shut off.

Operate the entire cooling system at least one complete cycle.

*If thermostat fails any test, refer to the Troubleshooting Guide in the Owner's Manual.*

Reset both temperature setting levers to the desired temperatures.

### HEATING/COOLING SYSTEM

Turn on power to the furnace and cooling system.

Place the system switch lever to HEAT and fan switch lever to AUTO.

Push both temperature setting levers together at least 5° F [3° C] above room temperature. The main burner should come on. The fan will start when the furnace heats up. (If central electric heat, fan coil or heat pump system, fan starts immediately.)

Move both levers 5° F [3° C] below room temperature. The burner should shut off.

Place the system switch lever to COOL and the fan switch lever to AUTO. The cooling equipment will operate, and the fan will start. Allow for any time delay that may be built into the compressor control circuit.

NOTE: To avoid compressor damage, do not operate the system when outdoor temperature is below 50° F [10° C]. Refer to manufacturer recommendations.

Move both temperature setting levers together at least 5° F [3° C] above the room temperature. The cooling equipment should shut off.

Place the fan switch to ON. The fan should run continuously with the system switch in any position.

Place the system switch to OFF. Move both temperature setting levers to various positions. The heating and cooling systems should not operate.

Operate the entire system for at least one complete cycle with the system switch at COOL and one complete cycle with the switch at HEAT.

*If thermostat fails any test, refer to the Troubleshooting Guide in the Owner's Manual.*

Reset both temperature setting levers to the desired temperatures.

*Leave Owner's Manual and Assistance Information in a convenient place for the building occupant or provide with other appliance manuals.*

## Calibration

### THERMOMETER

The thermometer in your thermostat was accurately calibrated at the factory. The thermometer should need adjustment only if it has been dropped or shifted due to mishandling. If the setpoint lever and the thermometer reading do not agree:

1. Remove the thermostat cover by pulling up from the bottom of cover until it clears the mounting slots.
2. Set the thermostat cover on a table near an accurate thermometer.
3. Allow five minutes for cover thermometer to sense area temperature; compare the readings. Be careful not to touch thermometer or breathe on it.
4. If the readings are the same, replace cover and put the system into operation.
5. If the readings are different, insert a small screwdriver in the thermometer and turn it until the thermometers have the same reading (Fig. 13).
6. Replace thermostat cover and put the system into operation.

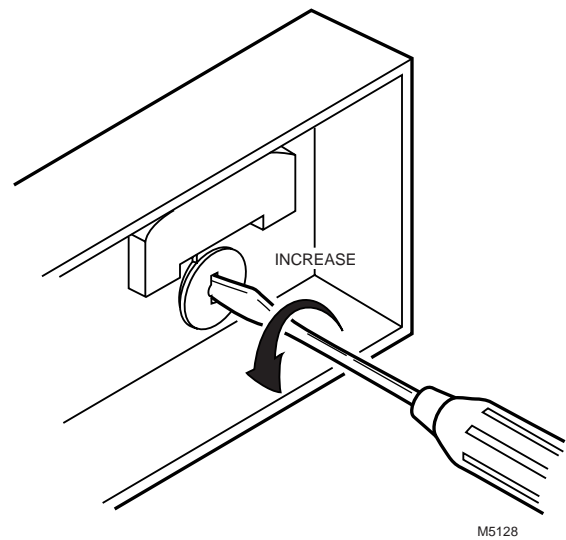
NOTE: Radiant heat from your hands will offset the thermometer reading. After making each adjustment, wait five or ten minutes for the thermometer to stabilize before comparing.

### THERMOSTAT

This thermostat was calibrated at the factory and should not need recalibration in the field. If recalibration seems necessary, first be sure wallplate or subbase is accurately leveled. Then check thermometer calibration.

To check thermostat calibration, allow several hours of operation after installation. Then read thermometer and remove cover. Push temperature levers together to a setting below room temperature. Slowly move them up the scale together until the mercury slides across the tube. *If the thermometer reading and the high temperature lever position are approximately the same at the instant the mercury moves to the other end, no recalibration is needed.*

Fig. 13—Thermometer calibration.



M5128

If calibration is necessary, proceed as follows:



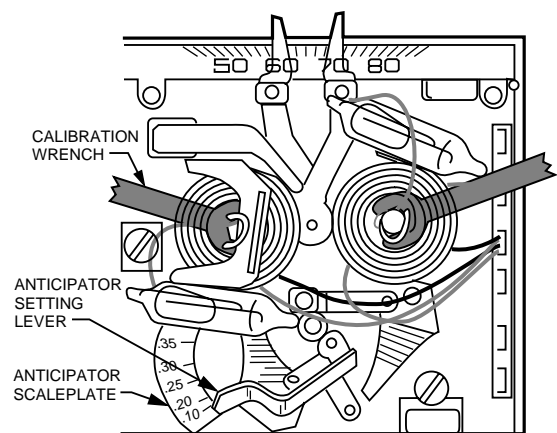
1. Remove the cover.
2. Place open-end calibration wrench, part no. 104994A (ordered separately), on the hex nut under the bimetallic coil controlled by the red lever (Fig. 14). Hold lever so it does not move, and gently turn the wrench clockwise  until the mercury rests securely in the right end of the tube.
3. Put the thermostat cover on and wait ten minutes.
4. Read the thermometer. Then remove the cover. Moving both levers, place the HIGH lever at the thermometer reading. Hold lever so it does not move, and gently turn the wrench counterclockwise  until the mercury just slides to the left end of the tube but no farther. Try to do this quickly so the heat from your hands does not affect the thermostat.
5. Repeat this procedure for the blue lever.

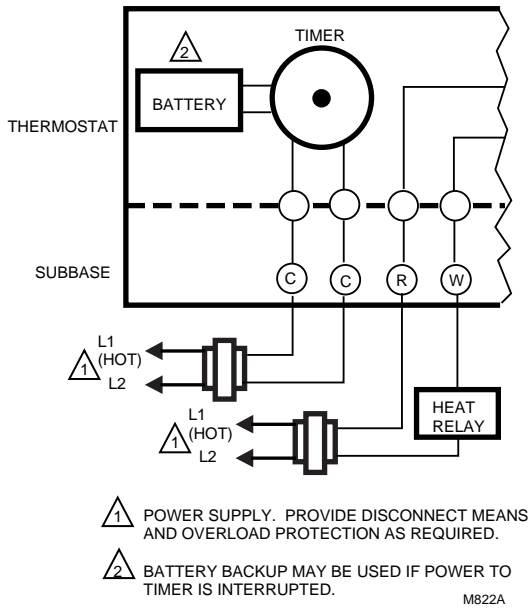
Fig. 14—Use of 104994A calibration wrench.



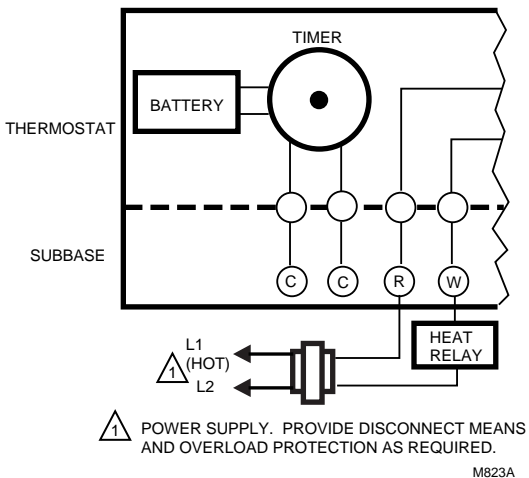
M8583

# Typical Wiring Diagrams

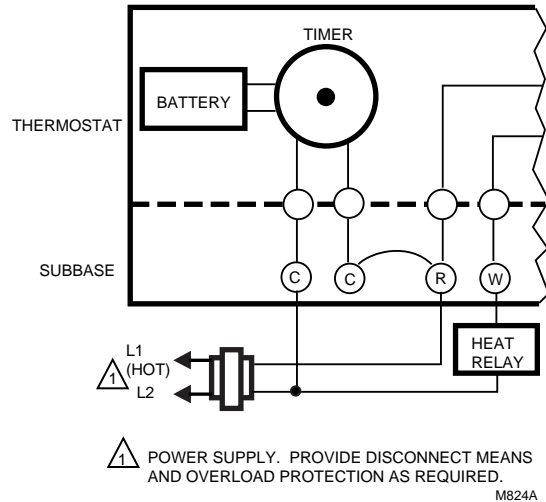
**Fig. 15—Typical hookup for timer powered by separate 24-Vac transformer.**



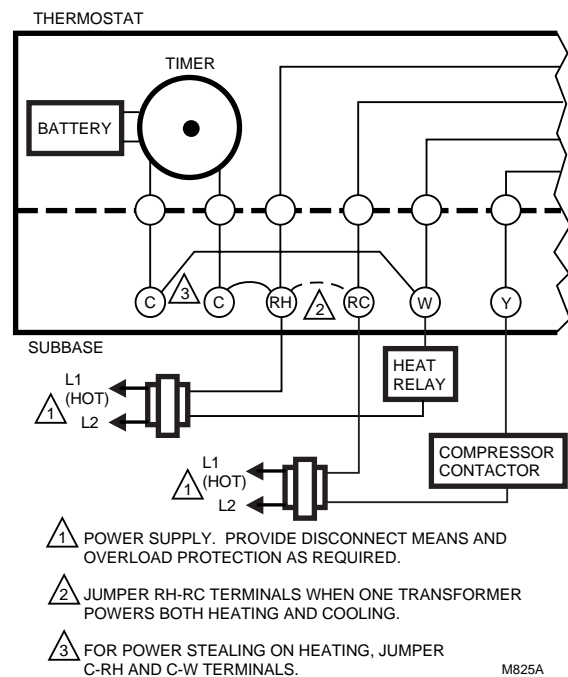
**Fig. 16—Typical hookup for timer powered by two AAA alkaline batteries only.**



**Fig. 17—Typical hookup for timer powered by system transformer. Timer powered by battery when system is not powered (e.g., power to system is off or interrupted).**

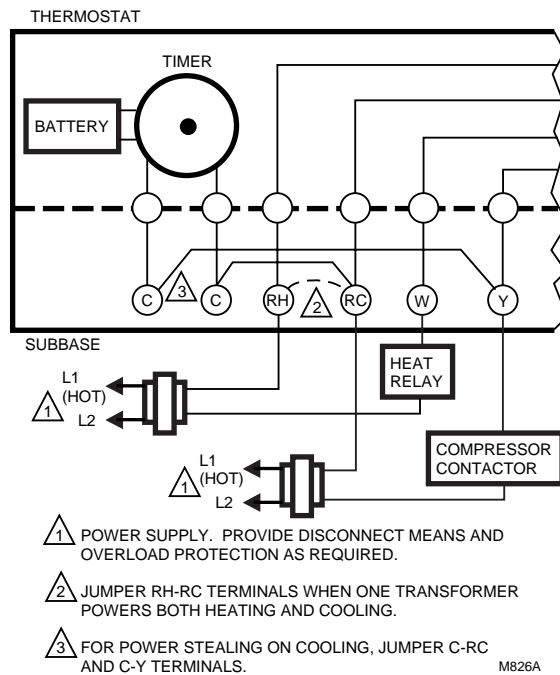


**Fig. 18—Typical hookup for timer powered through control system. Timer powered by battery when heating or cooling equipment is on; timer takes power from system when heating equipment is off.**

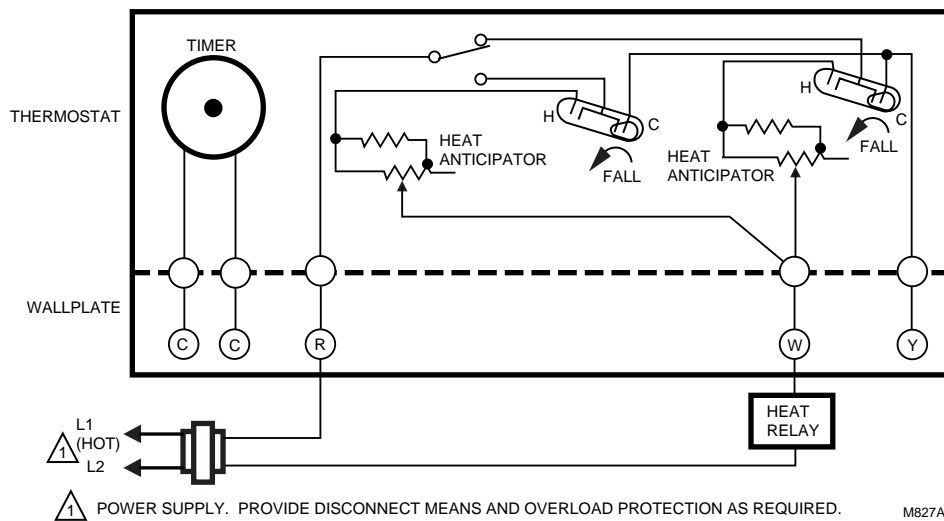




**Fig. 19—Typical hookup for timer powered through control system. Timer powered by battery when heating or cooling equipment is on; timer takes power from system when cooling equipment is off.**



**Fig. 20—Internal schematic and typical hookup for T8190A Thermostat/191108AJ Wallplate in heating-only system.**







**Honeywell**

*Helping You Control Your World*

**Home and Building Control**

Honeywell Inc.  
1985 Douglas Drive North  
Golden Valley, MN 55422

**Home and Building Control**

Honeywell Limited—Honeywell Limitée  
740 Ellesmere Road  
Scarborough, Ontario  
M1P 2V9

QUALITY IS KEY

Printed in Mexico